

# WASAGA

# D560

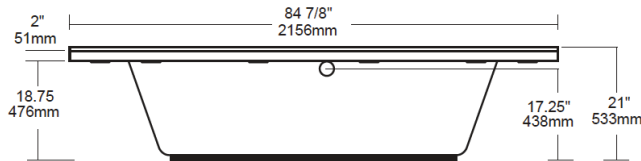
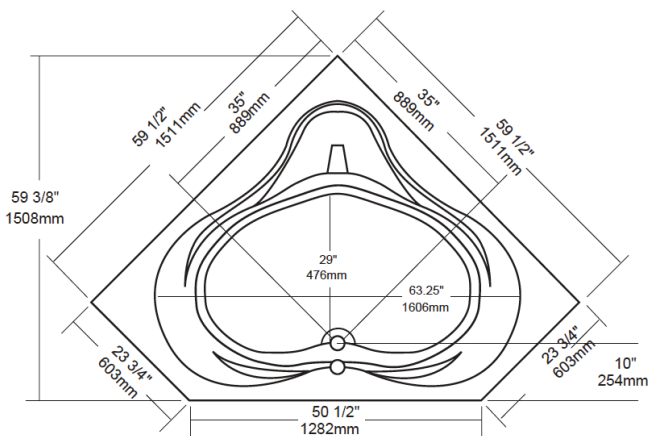

- DOUBLE-REINFORCED BASE
- DEEP SOAKING AREA
- CSA APPROVED
- CAN/ULC-S102 TESTED

Available with WHIRLPOOL, THERAPEUTIC AIR-FORCE, or COMBINATION options

TEL: (905) 470-9066  
FAX: (905) 470-9663  
TOLL-FREE: +1 (800) 561-0187

TUBCO WHIRLPOOLS LTD.

2715 14th Avenue  
Markham ON, L3R 0H9

tubco.com  
marketing@tubco.com